

Maßblatt GEKONORM Typ 50-200 NM

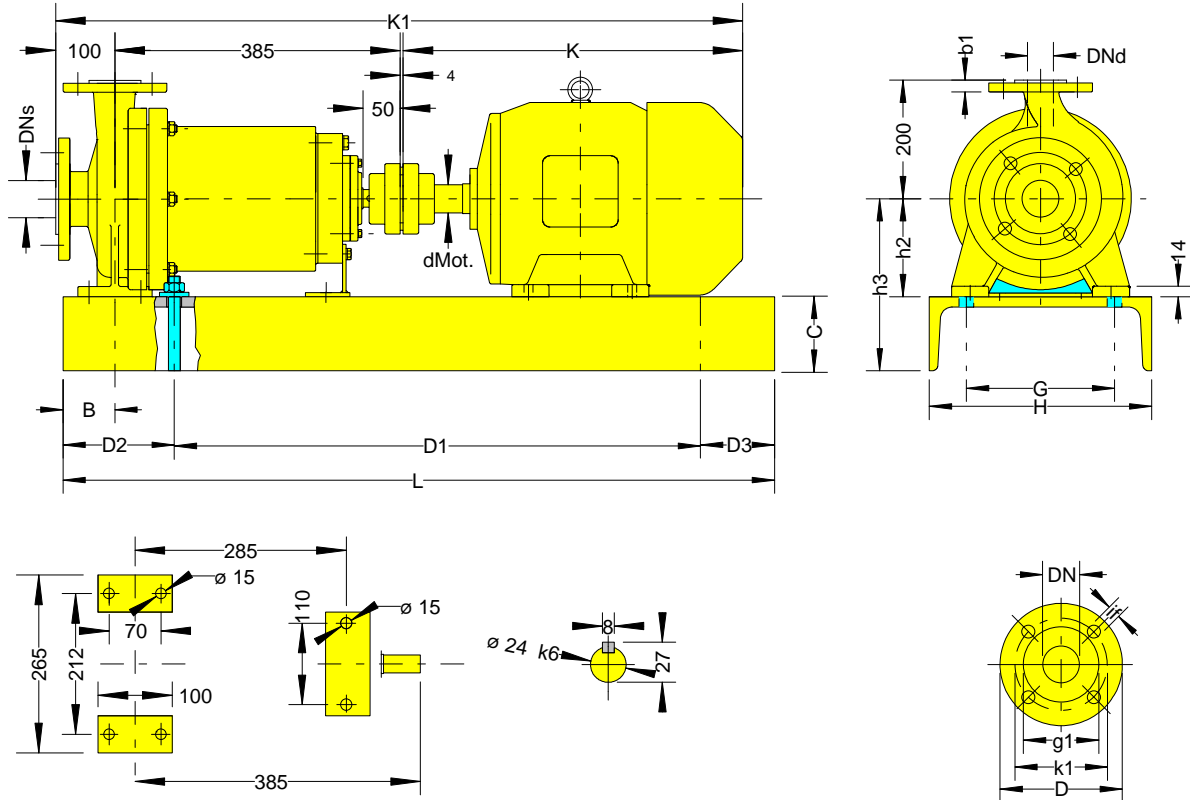

Pumpen- größe	DN _s	DN _d
50-200	80	50

Flanschanschlußmaße DIN 2533/PN16						
DN	D	k1	g1	i _f	b1	z1
50	165	125	102	18	16	4
80	200	160	138	18	18	8

z1 = Lochanzahl

Typ	Motor	Grundplattenmaße											Fundament- schrauben DIN 529		
		H	D2	D3	D1	L	G	C	B	K	K1	h2		h3	∅ dM
G2	132S	350	150	100	710	960	250	100	70	458	947	160	260	38	M16 x 220
G2	132M	350	150	100	710	960	250	100	70	496	985	160	260	38	M16 x 220
G3	160M	400	185	60	835	1080	280	110	100	628	1117	160	270	42	M20 x 220
G3	160L	400	185	60	835	1080	280	110	100	672	1161	160	270	42	M20 x 220
G3	180M	400	185	60	835	1080	280	110	100	696	1185	180	290	48	M20 x 220
G4	200L	400	185	60	955	1200	280	110	100	766	1255	200	310	55	M20 x 220