

# Maßblatt GEKONORM Typ 32-160 NM

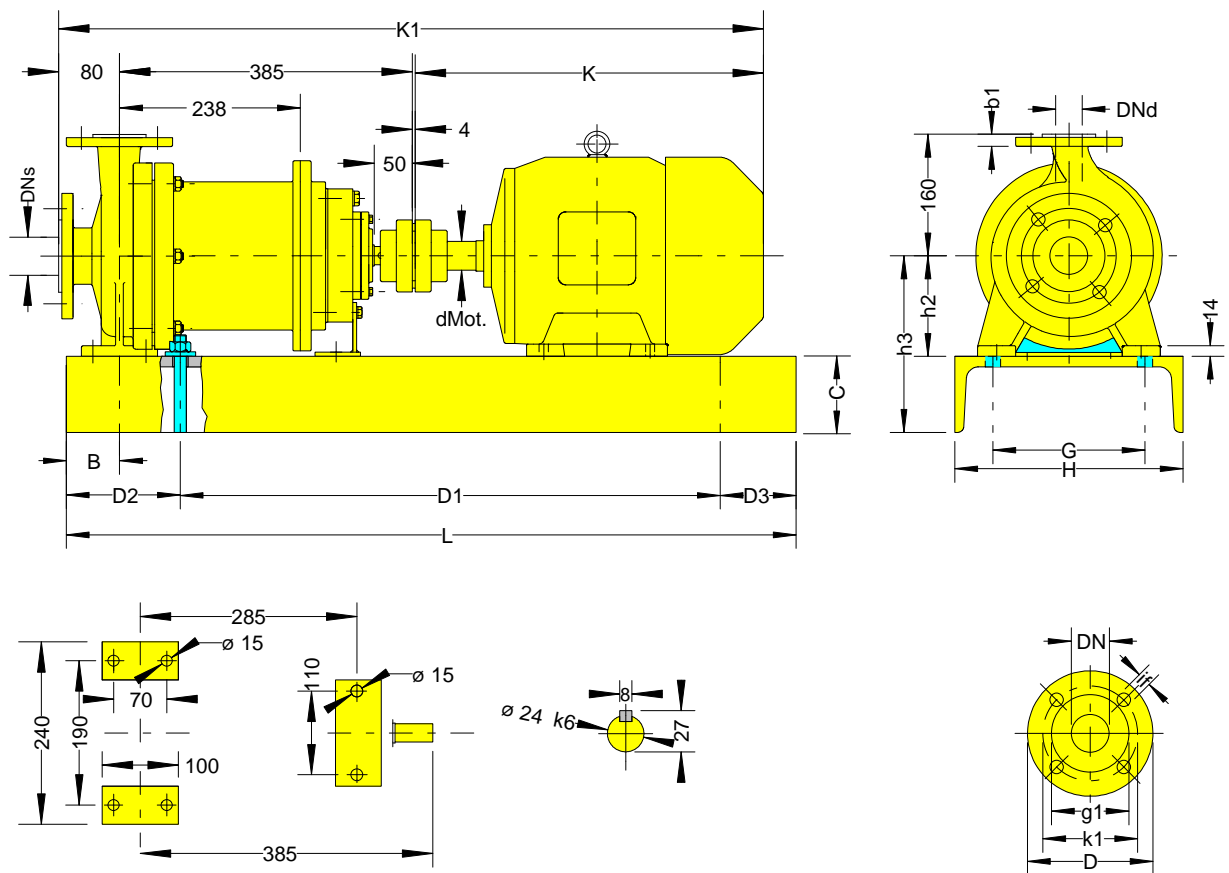

Pumpen- größe	DN <sub>s</sub>	DN <sub>d</sub>
32-160	50	32

Flanschanschlußmaße DIN 2533/PN16						
DN	D	k1	g1	i <sub>f</sub>	b1	z1
32	140	100	78	18	18	4
50	165	125	102	18	18	4

z1 = Lochanzahl

Größe	Motor	Grundplattenmaße											Ø dM	Fundament- schrauben DIN 529	
		H	D2	D3	D1	L	G	C	B	K	K1	h2			h3
G1	100L	300	150	100	620	870	190	100	70	383	852	132	232	28	M16 x 220
G1	112M	300	150	100	620	870	190	100	70	389	858	132	232	28	M16 x 220
G2	132S	350	150	100	710	960	250	100	70	458	927	132	232	38	M16 x 220
G3	160M	400	185	60	835	1080	280	110	100	628	1097	160	270	42	M20 x 220